

Mutina

Jali

by Patricia Urquiola



IT

Informazioni generali
Consigli di posa e manutenzione
Colori
Specifiche tecniche
Imballo

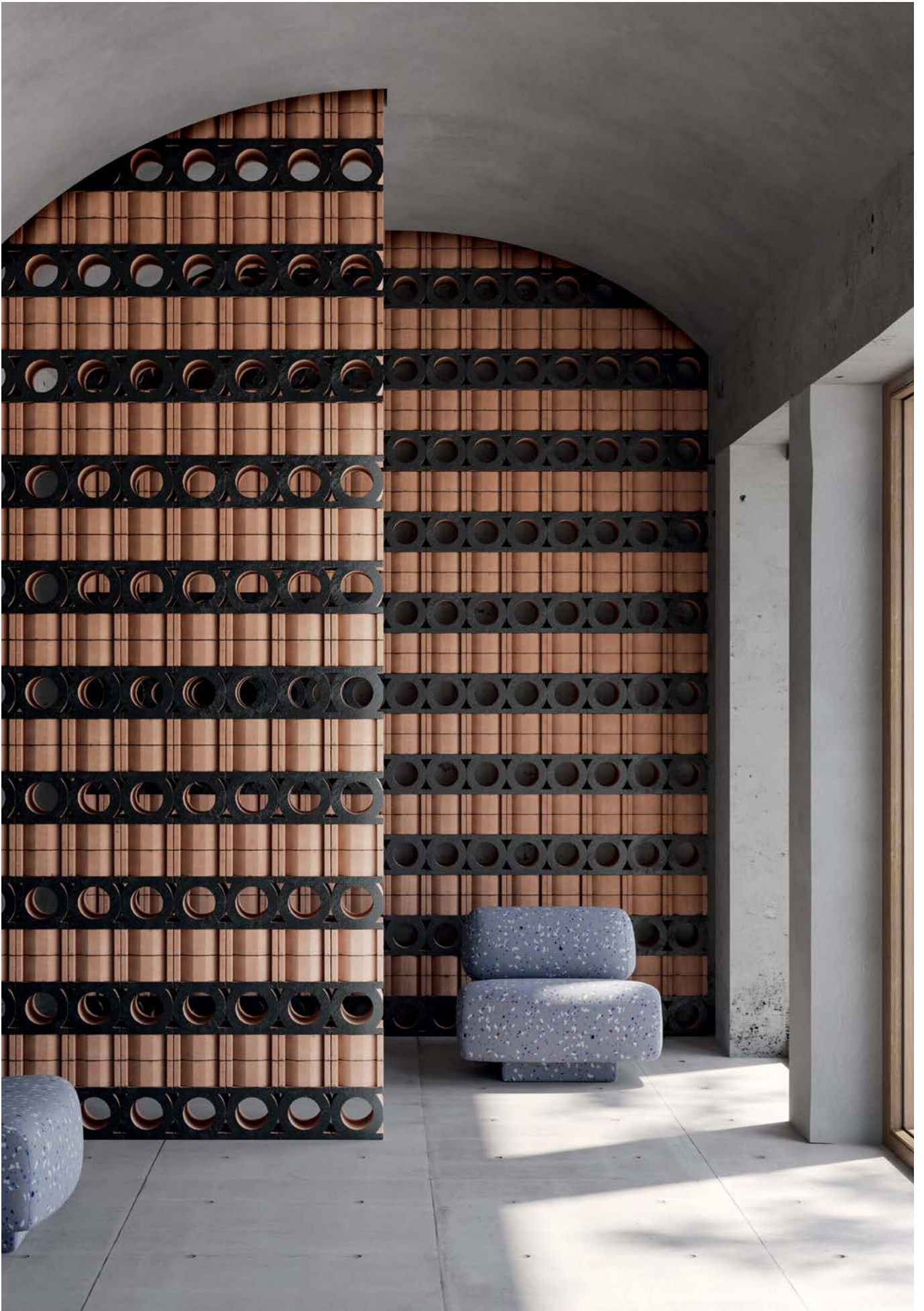

General information

The data, information and indications contained in this technical data sheet and in further documents relating to the Jali by Patricia Urquiola product are the exclusive property by Ceramiche MUTINA S.p.a. This Technical Data Sheet provides the buyer with information relating to the use of the product useful for its correct installation and evaluation and prevention of risks arising from the normal use of the same.

collection	Jali
design	Patricia Urquiola, 2023
production	Artisanal
material	Extruded terracotta
nominal sizes	24·12·24 cm (9"·4"·9")
awards	Interior Design Magazine's Best of Year Awards 2023 in the Category Architectural Products
specification	<p>– Artisanal extruded partition elements, 12 cm thick. – 3 Colors: Neutro, Bianco and Nero</p> <p>This product is suitable for both residential and commercial spaces to construct walls with a maximum height of 4 metres. The buyer is not released from the obligation of checking the information received, and for making design and construction choices in compliance with good construction techniques and regulations, including local ones, in force at the time of use of the product and in the country of final destination. The NTC 2018 DECRETO MIN 27/01 regulation shall apply in Italy.</p> <p>It is possible to install JALI with or without the aid of the wooden profile. In case you choose to use the accessory element, Mutina provides the EC 1 plus adhesive for VOC emissions.</p> <p>Jali is suitable for indoor and outdoor areas complying with UNI EN 772-22 marked "F1- moderate exposure".</p>
complementary pieces	Linear profile 300, top profile 300
category	UNI 11128/2004

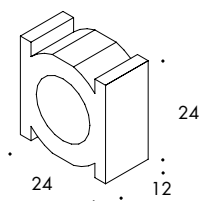

24·24·12cm
9"·4"·9"

complementary pieces

Linear painted wooden profile (also suitable for outdoor use).
Top painted wooden profile (also suitable for outdoor use) with one shaped end to make clamping easier

profile with vertical installation

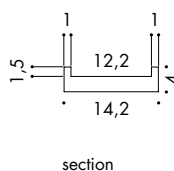
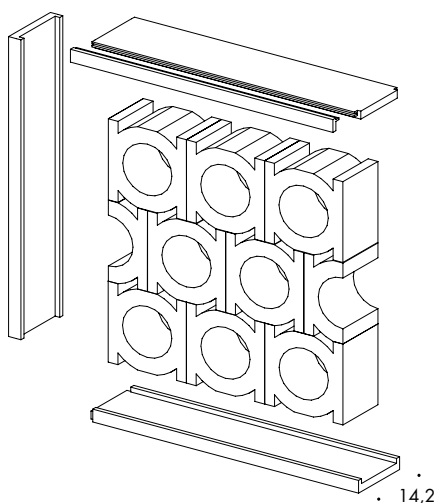

section

profile with horizontal installation

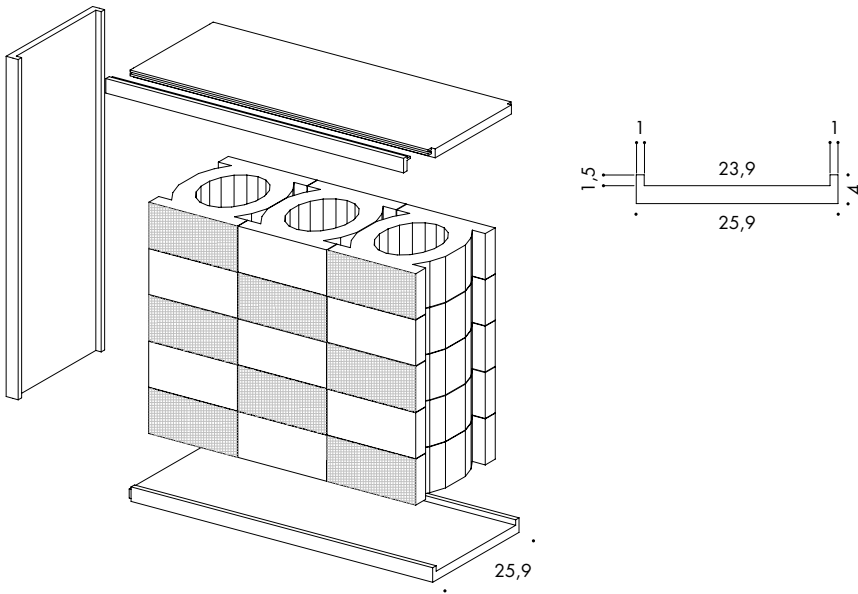

To ensure greater dimensional uniformity among the pieces, it is recommended to alternate the laying direction.

The buyer is responsible for verifying the information received and for ensuring that the design and construction decisions comply with proper construction techniques and regulations, including local laws applicable at the time of the product's use and in the country of its final destination.

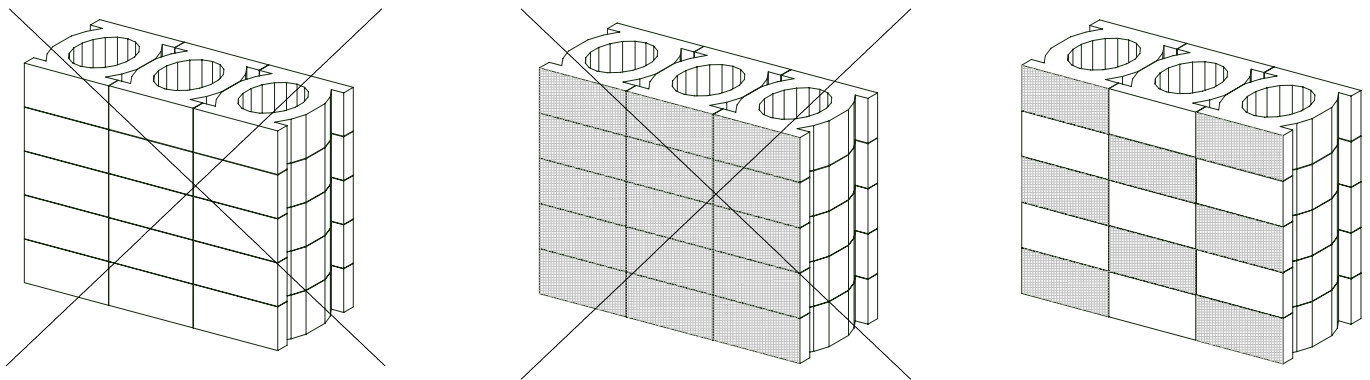

laying scheme

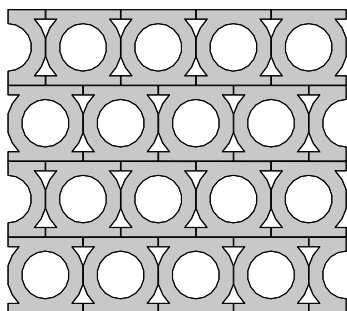

laying scheme 1
17,36 pcs / sqm

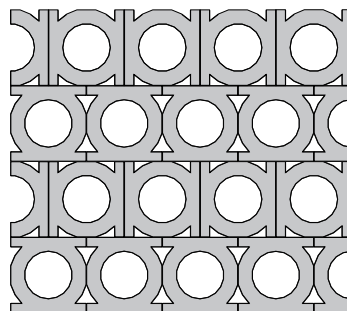

laying scheme 2
17,36 pcs / sqm

To ensure greater dimensional uniformity among the pieces, it is recommended to alternate the laying direction.

The buyer is responsible for verifying the information received and for ensuring that the design and construction decisions comply with proper construction techniques and regulations, including local laws applicable at the time of the product's use and in the country of its final destination.

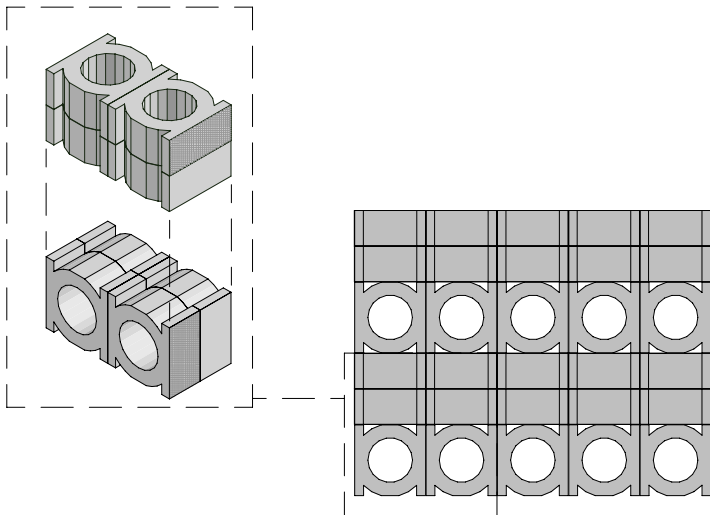

laying scheme 3
34,72 pz / mq

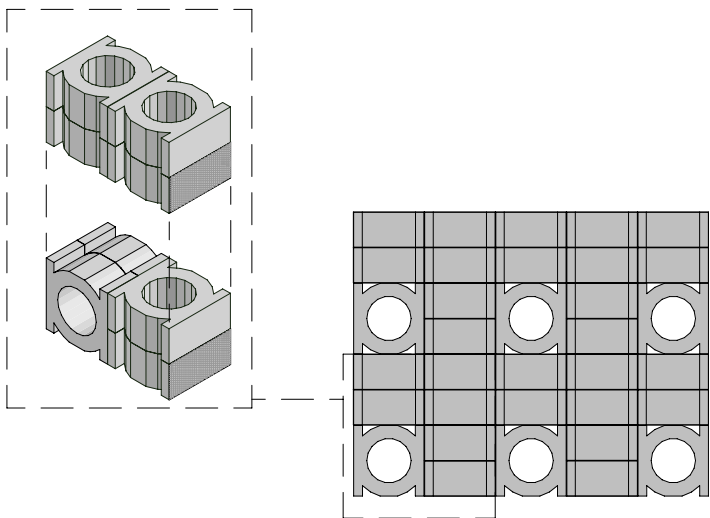

laying scheme 4
34,72 pz / mq

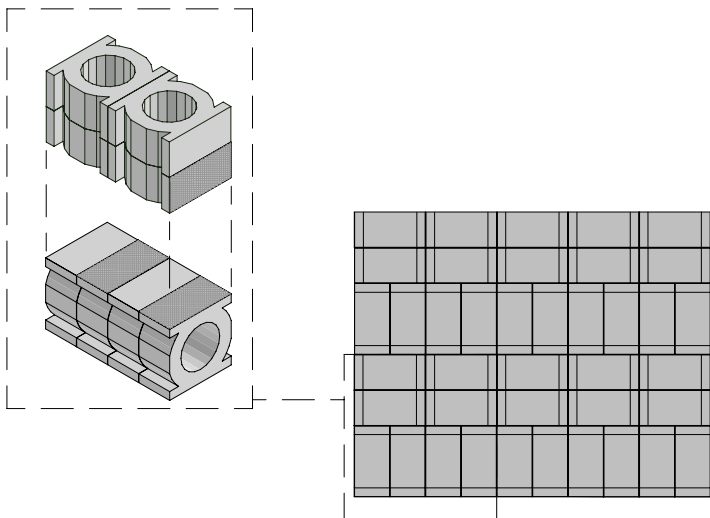

laying scheme 5
34,72 pz / mq

ANCHORING ON 2 SIDES
MAX h400 cm

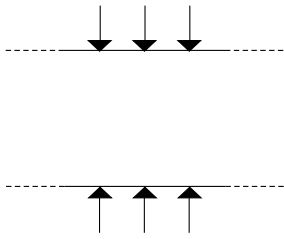

ANCHORING ON 3 SIDES
MAX h400x300 cm

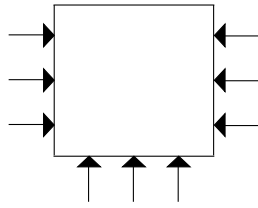

ANCHORING ON 2 SIDES
MAX h250x100 cm

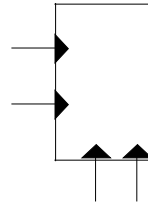

Laying and maintenance tips

use	Wall – indoor and outdoor areas complying with UNI EN 772-22 marked “F1-moderate exposure”.
recommended adhesive	Mutina adhesive: solvents-free, eco-friendly organic adhesive
recommended joints	–
recommended fillers	–
cleaning at the end of installation	Avoid drippings during installation. If needed the excess can be removed after the product has dried, using a tool with a sharp edge.
general cleaning (installed tiles)	–
calibers (real size)	24-24-12 cm with 1-3 mm tolerance (artisanal product)

Colors



Neutro



Nero



Bianco

Technical features

STANDARD	FEATURES	VALUE REQUIRED	JALI
UNI EN 772-16	dimensions	to declare	T2 – R2
UNI EN 772-21:2011	water absorption	to declare	12.5%
UNI EN 772-5:2016	content of active soluble salts	to declare	S2
UNI EN CEN/TS 772- 22:2006	freeze-thaw resistance	to declare	F1
D.M. 1401/2008	determination of horizontal variable loads	to declare	C2
LEED CERTIFICATION 4.1			10% recycled material
VOC EMISSION			available upon request
DECLARATION OF CONTENTS			available upon request
SDS			available upon request
BPD3			available upon request
HDP			available upon request

Packing

SIZE	PCS-SQM	PCS-BOX	BOX-PAL	SQM-PAL	PCS-PAL	KG-PC	KG-PAL
neutro	-	-	-	3,69	64	8,20	535
bianco, nero	-	2	36	4,15	72	8,20	600
laying scheme 1	17,36						
laying scheme 2	17,36						
laying scheme 3	34,72						
laying scheme 4	34,72						
laying scheme 5	34,72						